

S3010E

SELF PROPELLED MINI SCISSOR



- Compact & lightweight electric mini scissor lift
- Can be driven at full height
- Zero inside turning radius
- Drives through a standard doorway
- Ideal for low-level interior installation and maintenance applications

 **snorkel**
www.snorkellifts.com

SELF PROPELLED MINI SCISSOR

S3010E

DIMENSIONS	S3010E
Max. working height	15 ft 11 in
Max. platform height (A)	9 ft 11 in
Platform size	43 in x 20 in
Overall width (B)	30.3 in
Overall length (C)	49.6 in
Stowed height (D)	5 ft 11 in
Ground clearance	2.3 in

PERFORMANCE	
Platform capacity (SWL)	500 lbs
Max. wind speed	0 mph
Max. drive height	9 ft 11 in
Max. drive speed (stowed)	2.2 mph
Max. drive speed (elevated)	0.4 mph
Raise/lower time	18/25 sec
Gradeability	25%
Inside turning radius	0 ft
Outside turning radius	4 ft 9 in
Tires	9 in non-marking rubber
Parking brake	2 wheel automatic
Drive system	DC direct drive
Controls	2-axis proportional joystick

POWER	
Power source	2 x 12V 105Ah
Battery charger	100-240V 50/60Hz Auto, 30Amp

WEIGHT	
Gross weight	1,091 lbs

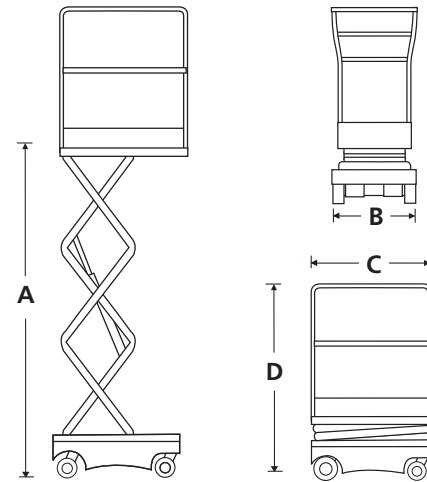

STANDARD FEATURES

- Highly maneuverable skid steer, zero inside turning radius
- Saloon-door style entry gates
- 1 person + equipment capacity indoors
- Non-marking tires
- Joystick proportional controls
- Integrated battery charger
- Battery condition indicator
- Crane points & through-the-chassis fork pockets
- Selectable motion alarm
- Tilt & descent alarm
- Hour meter
- Horn
- 2 year parts & labor, 5 year structural warranty
- ANSI compliant

OPTIONS

- Special paint colors
- CSA compliant

TURNING RADIUS

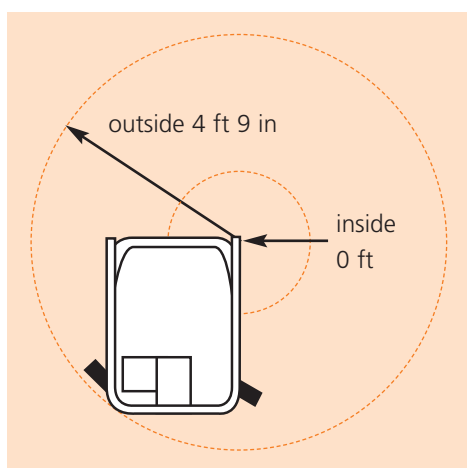

snorkel www.snorkellifts.com

P.O. Box 1160
 St. Joseph, MO 64502-1160, USA
 Tel: 1 (785) 989-3000
 Toll-free: 1 (800) 255-0317
 Fax: 1 (785) 989-3070
 Email: sales.usa@snorkellifts.com