

S3215E/S3219E

ELECTRIC SLAB SCISSOR LIFTS



- Self-propelled electric scissor lifts
- Compact & nimble
- Drives through a standard doorway
- Suitable for indoor and outdoor use
- Easy to use & maintain

 **snorkel**
www.snorkellifts.com

ELECTRIC SLAB SCISSOR LIFTS

S3215E/S3219E

DIMENSIONS	S3215E	S3219E
Max. working height	21 ft	25 ft
Max. platform height (A)	15 ft	19 ft
Platform size (stowed)	64.38 in x 27.13 in	64.38 in x 27.13 in
Platform size (extended)	100.38 in x 27.13 in	100.38 in x 27.13 in
Deck extension length	35.25 in	35.25 in
Overall length (C) (with step)	70.2 in	70.2 in
Overall length (C) (with step removed)	68.3 in	68.3 in
Overall width (D)	32 in	32 in
Stowed height (B)	75.25 in	78.75 in
Ground clearance (stowed)	2.5 in	2.5 in
Ground clearance (elevated)	0.75 in	0.75 in

PERFORMANCE	S3215E	S3219E
Platform capacity (SWL)	600 lbs	550 lbs
Max. wind speed	28 mph	28 mph
Max. drive height	15 ft	19 ft
Max. drive speed (stowed)	2.0 mph	2.0 mph
Max. drive speed (elevated)	0.4 mph	0.4 mph
Gradeability	25%	25%
Inside turning radius	4 in	4 in
Outside turning radius	64.25 in	64.25 in
Tires	12 x 4 non-marking solid rubber	
Controls	proportional	proportional
Drive system	2 wheel drive	2 wheel drive

POWER	S3215E	S3219E
Power source	24V DC battery electric	
Charger	90 - 240V, 25amp	90 - 240V, 25amp

WEIGHT	S3215E	S3219E
Weight	2,730 lbs*	2,900 lbs

TURNING RADIUS

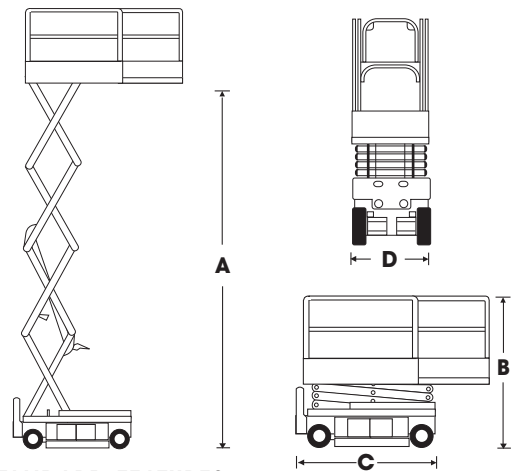
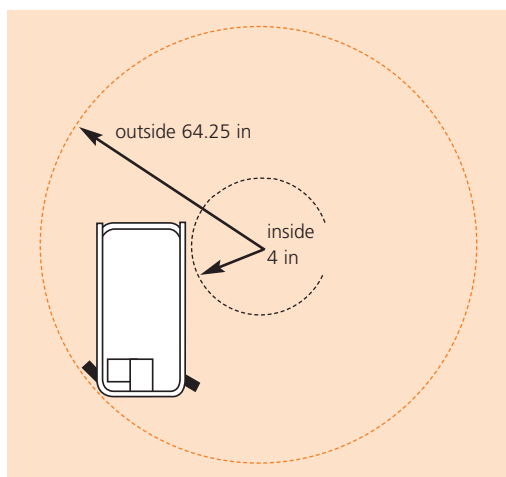

STANDARD FEATURES

- Roll-out deck extension with dual locks
- Non-marking tires
- Swing-out service trays
- Saloon-door style entry gates
- Descent alarm
- All motion alarm
- Key switch
- 2 persons + equipment capacity indoors
- 1 person + equipment capacity outdoors
- Proportional controls
- Power line to platform
- Hour meter & on-board diagnostics display
- Integrated battery charger
- Battery condition indicator
- Crane & forklift points
- Dual lanyard attachments points
- 2 year parts & labor, 5 year structural warranty
- ANSI compliant

OPTIONS

- Special paint colors
- Flashing amber light
- 110V AC 800W inverter
- Environmental (green) oil
- CSA compliant

snorkel www.snorkellifts.com

P.O. Box 1160
 St. Joseph, MO 64502-1160, USA
 Tel: 1 (785) 989-3000
 Toll-free: 1 (800) 255-0317
 Fax: 1 (785) 989-3070
 Email: sales.usa@snorkellifts.com