

S3220E/S3226E

ELECTRIC SLAB SCISSOR LIFTS



- Self-propelled electric scissor lifts
- Compact & robust
- Roll-out extension decks for extra reach
- Suitable for indoor and outdoor use
- Ideal for construction & maintenance applications

 **snorkel**
www.snorkellifts.com

ELECTRIC SLAB SCISSOR LIFTS

S3220E/S3226E

DIMENSIONS	S3220E	S3226E
Max. working height	26 ft	32 ft
Max. platform height (A)	20 ft	26 ft
Platform size (stowed)	26 in x 86 in	26 in x 86 in
Platform size (extended)	26 in x 122 in	26 in x 122 in
Deck extension length (B)	36 in	36 in
Overall length (D) (with step)	90.6 in	90.6 in
Overall length (D) (step removed)	89 in	89 in
Overall width (C)	32 in	32 in
Stowed height (E)	83 in	90.5 in
Ground clearance (stowed)	3 in	3 in
Ground clearance (elevated)	0.75 in	0.75 in

PERFORMANCE	S3220E	S3226E
Platform capacity	900 lbs	500 lbs
Max. wind speed	28 mph	28 mph
Max. drive height	20 ft	26 ft
Max. drive speed (elevated)	0.4 mph	0.4 mph
Max. drive speed (stowed)	2.0 mph	2.0 mph
Gradeability	25%	25%
Inside turning radius	30 in	30 in
Outside turning radius	93 in	93 in
Tires	15 x 4 non-marking rubber	15 x 4 non-marking rubber
Controls	proportional	proportional
Drive system	2 wheel drive	2 wheel drive

POWER	S3220E	S3226E
Power source	24V DC battery electric	
Charger	90-240V, 25amp	

WEIGHT	S3220E	S3226E
Weight	4,500 lbs*	5,000 lbs

TURNING RADIUS

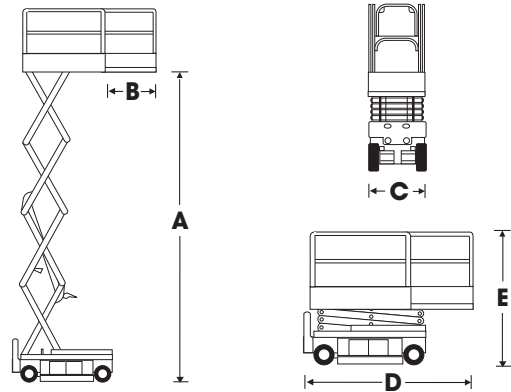
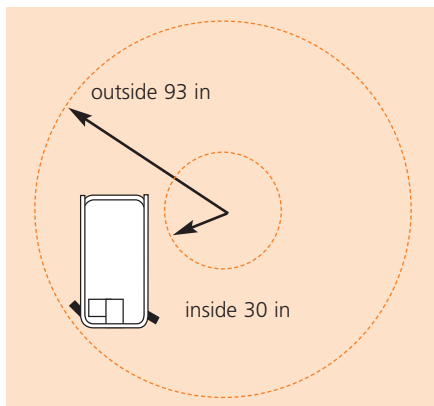

STANDARD FEATURES

- Roll-out deck extension with dual locks
- Non-marking tires
- Swing-out service trays
- Saloon-door style entry gates
- Descent alarm
- All motion alarm
- Key switch
- 2 persons + equipment capacity indoors
- 1 person + equipment capacity outdoors
- Proportional controls
- Power line to platform
- Hour meter & on-board diagnostics display
- Integrated battery charger
- Battery condition indicator
- Crane & forklift points
- Dual lanyard attachment points
- 2 year parts & labor, 5 year structural warranty
- ANSI compliant

OPTIONS

- Special paint colors
- Flashing amber light
- 110V AC 800W inverter
- Environmental (green) oil
- CSA compliant

snorkel

www.snorkellifts.com

P.O. Box 1160
 St. Joseph, MO 64502-1160, USA
 Tel: 1 (785) 989-3000
 Toll-free: 1 (800) 255-0317
 Fax: 1 (785) 989-3070
 Email: sales.usa@snorkellifts.com

ANSI Specification ©Snorkel 2016 Specifications subject to change without notice. Photos and diagrams in this brochure are for promotional purposes only. Refer to appropriate Snorkel operators manual for detailed instructions on the proper use and maintenance.

*Preliminary weight - confirm at time of ordering.