

S4726E/S4732E

ELECTRIC SLAB SCISSOR LIFTS



- Self-propelled electric scissor lifts
- Compact & robust
- Roll-out extension decks for extra reach
- Suitable for indoor and outdoor use
- Ideal for construction & maintenance applications

 **snorkel**
www.snorkellifts.com

ELECTRIC SLAB SCISSOR LIFTS S4726E/S4732E

DIMENSIONS	S4726E	S4732E
Max. working height	32 ft	38 ft
Max. platform height (A)	26 ft	32 ft
Platform size (stowed)	86 in x 41.5 in	86 in x 41.5 in
Platform size (extended)	134 in x 41.5 in	134 in x 41.5 in
Deck extension length (B)	48 in	48 in
Overall length (D) (with step)	90.6 in	90.6 in
Overall length (D) (step removed)	89 in	89 in
Overall width (C)	47 in	47 in
Stowed height (E)	90.5 in	95 in
Min. height (guardrails folded)	73 in	76.5 in
Ground clearance (stowed)	3 in	3 in
Ground clearance (elevated)	0.75 in	0.75 in

PERFORMANCE	S4726E	S4732E
Platform capacity	1,000 lbs	700 lbs
Max. wind speed	28 mph	28 mph
Max. drive height	26 ft	32 ft
Max. drive speed (stowed)	2.0 mph	2.0 mph
Max. drive speed (elevated)	0.4 mph	0.4 mph
Gradeability	25%	25%
Inside turning radius	10 in	10 in
Outside turning radius	91 in	91 in
Tires	15 in x 5 in non-marking rubber	
Controls	proportional	proportional
Drive system	2 wheel drive	2 wheel drive

POWER	S4726E	S4732E
Power source	24V DC battery electric	
Charger	90-240V, 25amp	

WEIGHT	S4726E	S4732E
Weight	4,400 lbs	5,550 lbs

TURNING RADIUS

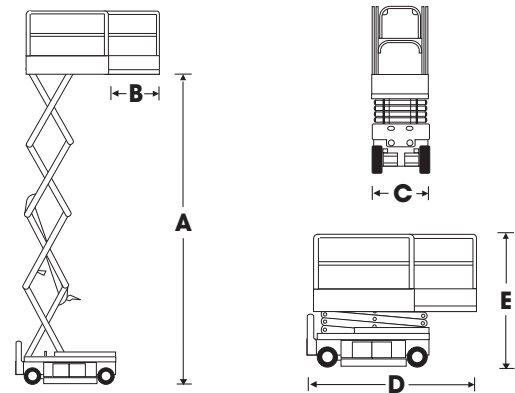
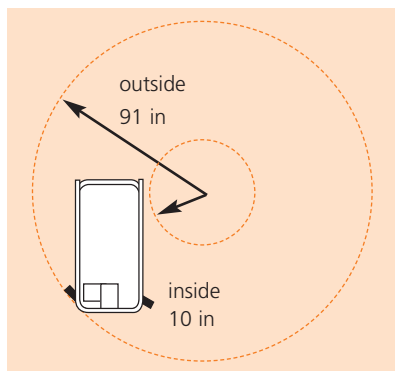

STANDARD FEATURES

- Roll-out deck extension with dual locks
- Non-marking tires
- Swing-out service trays
- Saloon-door style entry gates
- Descent alarm
- All motion alarm
- Key switch
- 2 persons + equipment capacity indoors
- 1 person + equipment capacity outdoors
- Proportional controls
- Power line to platform
- Hour meter & on-board diagnostics display
- Integrated battery charger
- Battery condition indicator
- Crane & forklift points
- Dual lanyard attachment points
- 2 year parts & labor, 5 year structural warranty
- ANSI compliant

OPTIONS

- Special paint colors
- Flashing amber light
- 110V AC 800W inverter
- Airline to platform
- Aircraft bumpguard package
- Panel carrier
- Environmental (green) oil
- CSA compliant

snorkel

www.snorkellifts.com

P.O. Box 1160
 St. Joseph, MO 64502-1160, USA
 Tel: 1 (785) 989-3000
 Toll-free: 1 (800) 255-0317
 Fax: 1 (785) 989-3070
 Email: sales.usa@snorkellifts.com