

TB80/TB86J

TELESCOPIC BOOM LIFTS



- Robust diesel telescopic boom lifts
- Available with and without a jib boom
- Powerful 4 wheel drive and 4 wheel steer
- Excellent performance on rough terrain
- Designed for construction applications

 **snorkel**
www.snorkellifts.com

TELESCOPIC BOOM LIFTS

TB80/TB86J

| DIMENSIONS | TB80 | TB86J |
|-----------------------|-------------|-------------|
| Max. working height | 86 ft | 92 ft |
| Max. platform height | 80 ft | 86 ft |
| Max. horizontal reach | 71 ft 2 in | 78 ft 3 in |
| Platform size | 8 ft x 3 ft | 8 ft x 3 ft |
| Overall width (A) | 8 ft 6 in | 8 ft 6 in |
| Overall length (B) | 38 ft 8 in | 42 ft 3 in |
| Stowed height (C) | 9 ft 6 in | 9 ft 6 in |
| Ground clearance | 13 in | 13 in |

| PERFORMANCE | TB80 | TB86J |
|-----------------------------|--------------------------|-----------------|
| Platform capacity (SWL) | 500 lbs | 500 lbs |
| Max. drive height | 80 ft | 84 ft 11 in |
| Max. wind speed | 28 mph | 28 mph |
| Max. drive speed (stowed) | 2.9 mph | 2.9 mph |
| Max. drive speed (elevated) | 0.6 mph | 0.6 mph |
| Jib length | n/a | 6 ft 6 in |
| Jib working arc | n/a | 135° |
| Platform rotation | 157° | 150° |
| Superstructure rotation | 360° continuous | 360° continuous |
| Tailswing | 79.5 in | 79.5 in |
| Raise/lower time | 195/175 seconds | 230/210 seconds |
| Gradeability | 40% | 40% |
| Inside turning radius | 7 ft 10 in | 7 ft 10 in |
| Outside turning radius | 15 ft 6 in | 15 ft 6 in |
| Tires | 15 x 625 foam filled lug | |
| Controls | proportional joystick | |
| Drive system | 4 wheel drive | |

| POWER | TB80 | TB86J |
|--------------|---|-------|
| Power source | Kubota 59hp Tier 4i Flex V2403 Turbo Diesel | |

| WEIGHT | TB80 | TB86J |
|--------|------------|------------|
| Weight | 36,500 lbs | 38,000 lbs |

WORKING ENVELOPE

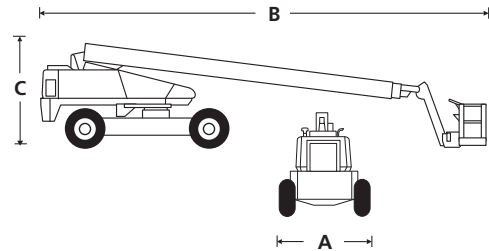
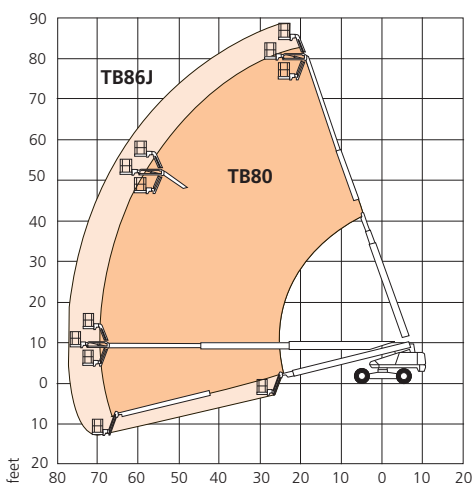

STANDARD FEATURES

- Snorkel Guard™ secondary guarding system
- Four wheel drive, steer and crab steer
- Hydraulic platform rotation
- 360° continuous turntable rotation
- Drive motion alarm
- Flashing amber light
- Foam filled lug tires
- Proportional drive, boom lift, swing & extend
- Rheostat control for jib & platform level
- Power line to platform
- 5° tilt alarm
- Tri-entry platform
- Dual lanyard attachment points
- Horn
- 2 year parts & labor, 5 year structural warranty
- ANSI compliant

OPTIONS

- Special paint colors
- Airline to platform
- AC generator 110V/240V
- Non-marking tires
- Cold weather package
- Extreme cold weather package
- Extreme environment package
- Light package
- Tow package
- Glazier package
- 12k generator package
- 12k generator/welder package
- CSA compliant

snorkel

P.O. Box 1160
 St. Joseph, MO 64502-1160, USA
 Tel: 1 (785) 989-3000
 Toll-free: 1 (800) 255-0317
 Fax: 1 (785) 989-3070
 Email: sales.usa@snorkellifts.com

www.snorkellifts.com