

TM12

SELF-PROPELLED TELESCOPIC MAST LIFT



- Industry-leading self-propelled telescopic mast lift
- Versatile, robust and simple to use
- Drives through a standard doorway
- 20 in roll-out extension deck
- Ideal for many applications – from construction to stockpicking

 **snorkel**
www.snorkellifts.com

SELF-PROPELLED TELESCOPIC MAST LIFT **TM12**

DIMENSIONS	TM12
Max. working height	17 ft 11 in
Max. platform height (A)	11 ft 11 in
Platform size (stowed)	29 in x 38 in
Platform size (extended)	29 in x 58 in
Extension deck length	20 in
Overall length (D)	4 ft 5 in
Overall width (B)	2 ft 6 in
Stowed height (C)	5 ft 4 in
Ground clearance	3 in

PERFORMANCE	
Platform capacity (SWL)	500 lbs
Max. drive height	11 ft 11 in
Max. wind speed	28 mph
Max. drive speed (stowed)	2.0 mph
Max. drive speed (elevated)	0.4 mph
Raise/lower time	16/19 sec
Gradeability	25%
Max. operating slope (side to side)	1.5°
Max. operating slope (front to back)	2°
Inside turning radius	14.4 in
Outside turning radius	58.5 in
Tires	11 in. non-marking rubber
Parking brake	2 wheel, spring-applied, hydraulically-released with manual overdrive
Drive system	dual front hydraulic motors
Controls	proportional

POWER	
Power source	24V 4hp DC electric motor 4-220 Ah batteries
Battery charger	18 Amp

WEIGHT	
Weight	1,830 lbs

TURNING RADIUS

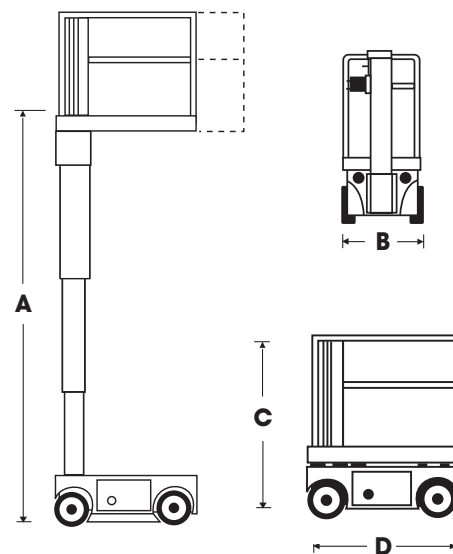
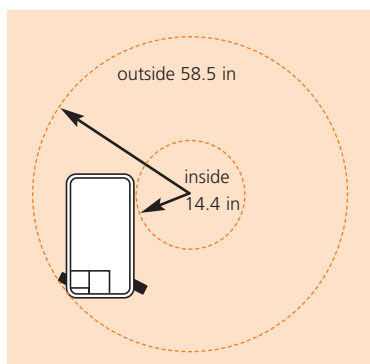

STANDARD FEATURES

- Roll-out deck extension
- Hydraulically powered descent
- Proportional controls
- Saloon-door style entry gates
- Descent & tilt alarms
- Emergency lowering at chassis controls
- Non-marking rubber tires
- Crane lift points
- Horn
- Selectable motion alarm
- Integrated battery charger 90V-240V 25A
- 2 year parts & labor, 5 year structural warranty
- ANSI compliant

OPTIONS

- Special paint colors
- Environmental (green) oil

snorkel

www.snorkellifts.com

P.O. Box 1160
 St. Joseph, MO 64502-1160, USA
 Tel: 1 (785) 989-3000
 Toll-free: 1 (800) 255-0317
 Fax: 1 (785) 989-3070
 Email: sales.usa@snorkellifts.com